

RP-35A

Autozeroing Panel Meter
3 1/2 Digit 0.56" LED
In a NEMA Style Case



A Precision AC-Powered Differential Meter for DIN/NEMA Cutouts.

General Features

The Texmate Model RP-35A is a precision, autozeroing 3½ digit meter designed to fit most other manufacturers' panel cutouts, including DIN/NEMA standard. It measures bipolar differential and single-ended DC voltages over five user-programmable ranges from ±199.9 mV to ±1200 V full-scale. Provision has been made for offset capability, as well as for various operating modes, such as a ratiometric ohmmeter, ratiometric voltmeter, current meter, and temperature meter. For 4-20 mA applications, the suggested meter, in the same case size is the UM-35CL.

The UM-Series also has temperature, pressure, AC Volts and AC Amp meters that are in the same case size as the RP-35A.

Typical Application Connections

SINGLE ENDED METER - 200mV RANGE, >2V RANGE
200mV Range: Omit R1 and R2; 2) Change R9 from 18.2kΩ to 26.7kΩ; 3) Change R6 from 470kΩ to 47KΩ; 4) Remove R8 (9.53kΩ) and short with a jumper; 5) It is recommended that C4, C5 and C7 be changed to 0.22mF; 6) Adjust R10 until CV1=100mV. >2V Range: 1) Install R1 and R2 as specified under section titled Useful Tables.

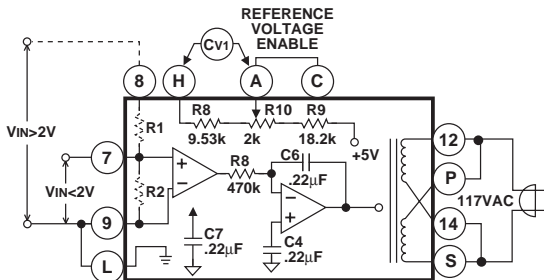

SINGLE-ENDED CURRENT METER

1) Connect meter as for 200mV voltmeter; 2) Install Rs. NOTE: Rs must be externally mounted when F.S. current is greater than 200mA, and 4-wire type connection should be used. For currents of 200mA F.S. or less RS, may be internally mounted in the R2 position. Standard values for RS are specified under section titled Useful Tables.

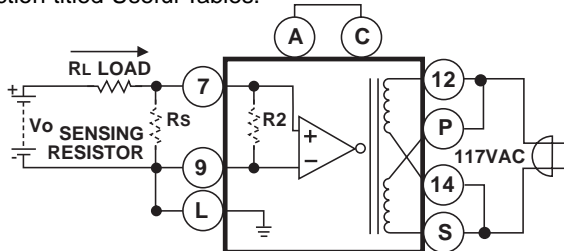

View more application connections and connection instructions on page 3.

Compatibility

The RP-Series NEMA case style is complementary to Texmate's Classic UM-Series. For economy, each RP model is dedicated to a specific application. RPs are ideal for upgrading or replacing the traditional USA NEMA case panel meters presently in use.

Traditional
NEMA
STYLE USA
CASE

Specifications

- Input Configuration:**..... True differential and single-ended
- Full Scale Ranges:**±199.9mVDC
±1.999VDC (standard)
±19.99VDC
±199.9VDC
±1200VDC
- Input Impedance:** Exceeds 1000MΩ on 200mV and 2V ranges; 10MΩ on all other ranges
- Input Protection:**.....±500VDC or 350VAC maximum on 200mV and 2V ranges; ±1200VDC or 850VAC on all other ranges
- Accuracy:**±(0.05% of reading = 1 digit)
- Temperature Coefficient:** ..5PPM/°C in ratiometric operation; 60 PPM/°C Typ. using internal reference on 200mV and 2V ranges
- Warm Up Time:** 10 minutes to specified accuracy
- Conversion Rate:** 3 readings per second nominal, controllable from 1 to 20 readings per second
- Display:** 0.56" LED
- Decimal Selection:** User programmable to 4 positions
- Overrange Indication:** ..When input exceeds full scale on any range being used, most significant "1" digit & "-" symbol (for negative inputs) is displayed with all other digits blanked
- Power Requirements:**..... 110V or 220V, ±5% at 50Hz; 117V or 230V, ±5% at 60 and 400Hz
- Operating Temperature:** -10° to +50°C
- Storage Temperature:**..... -20° to +70°C
- Relative Humidity** 95% (non-condensing)
- Case Dimensions:** Bezel 4.06"Wx1.89"H (102.7Wx47.9Hmm)
Depth behind bezel 3.64" (92.22 mm) Plus 0.5 to .9" (12.7 to 22.8mm) depending on connector used.
- Weight:** 8 oz (227 gms)

RP-Series, a reliable replacement for your application

RP-3500D23.5 digit Red LED Ultra Stable, Differential, 2VDC std
RP-3500D2BCDRP-3500D2 with Tri-State Parallel BCD, 2VDC std
RP-35A3.5 digit Red LED with Differential Inputs, 2VDC std
RP-35AR3.5 digit Red LED, Autoranging, 200mV / 2VDC

RP-35U3.5 digit Red LED, Low Cost, 2VDC std
RP-4500D24.5 digit RED LED Ultra Stable, Differential, 2VDC std
RP-4500D2BCDRP-4500D2 with Tri-State Parallel BCD, 2VDC std

Functional Diagram

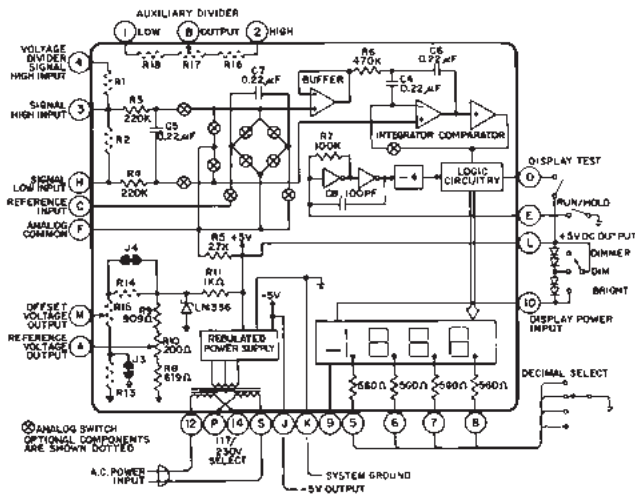

Connector Pinouts

The Texmate Model RP-35A interconnects by means of a standard PC board edge connector having two rows of 15 pins, on 0.156" centers. Connectors are available from Texmate, or from almost any connector manufacturer.

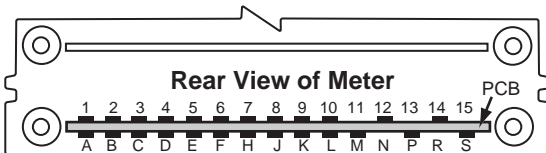

Component Side	Solder Side
AUXILIARY DIVIDER LOW 1	A REFERENCE VOLTAGE OUTPUT
AUXILIARY DIVIDER HIGH 2	B AUXILIARY DIVIDER OUTPUT
SIGNAL HIGH INPUT 3	C REFERENCE INPUT
VOLTAGE DIVIDER SIG HI IN 4	D DISPLAY TEST
DECIMAL SELECT (1.XXX) 5	E RUN/HOLD
DECIMAL SELECT (1X.XX) 6	F ANALOG COMMON
DECIMAL SELECT (1XX.X) 7	H SIGNAL LOW INPUT
DECIMAL SELECT (1XXX.) 8	J -5 V OUTPUT
NO CONNECTION 9	K SYSTEM GROUND
DISPLAY POWER INPUT 10	L +5 V POWER OUTPUT
NO CONNECTION 11	M OFFSET VOLTAGE OUTPUT
AC POWER INPUT 12	N NO CONNECTION
NO CONNECTION 13	R 117/230V SELECT
117/230V SELECT 14	R NO CONNECTION
NO CONNECTION 15	S AC POWER INPUT

Pin A – Reference Voltage Output: Internal precision voltage reference. Standard output is 1.000 V, adjustable by $\pm 5\%$ with R10 potentiometer. Usable voltages from 0.05 V to 2.5 V for special high-impedance scaling can be obtained by changing the value of internal dividing resistors R8 and R9.

Pin B – Auxiliary Divider Output: Pin B is the wiper of the optional R17 potentiometer located behind the front-panel filter on the right side. Solder pads for the optional divider network formed by R16, R17, and R18 have been provided for user convenience and the divider is intended for field installation. This divider can be used for any appropriate application, such as balancing a half-bridge transducer or providing trimmable input signal attenuation.

Pin C – Reference Input: Reference voltage input for A to D converter. Normally supplied from Reference Voltage Output Pin A. However, an external reference source referred to Analog Common Pin F may be used instead. Pin C may be used as an input for ratiometric measurements by connecting Analog Common Pin F to System Ground Pin K. (Signal Input Voltage \div Reference Input Voltage) \times 1000 = Displayed Reading. The maximum signal input voltage is 5 V. Higher voltages must be scaled down through a voltage divider. Reference input voltage must remain stable during measurement period.

Pin D – Display Test: All display segments will operate when Pin D is connected to +5 V Output Pin L.

Pin E – Run/Hold: If Pin E is left open, the meter will operate in a free-running mode. If Pin E is connected to System Ground Pin K, the inter-

nal R-C oscillator will be shorted and the meter will latch up, continuously displaying the reading. If Pin E is released from Pin K, it will take 3 to 4 conversions before the new reading settles.

Pin F – Analog Common: This is the floating common for the analog section of the meter. It is normally +2.2 V referenced to System Ground Pin K. For single-ended inputs, Pin F should be joined to grounded side of input signal.

Pin H – Signal Low Input: Signal low input of A to D converter. Maximum overvoltage protection is ± 500 VDC or 350 VAC.

Pin J – -5V Output: Auxiliary -5 V output at 50 mA maximum, produced by internal regulated power supply.

Pin K – System Ground: Pin K is the system ground and is common for all input and output circuits.

Pin L – +5 V Output: Auxiliary +5 V output at 50 mA maximum, produced by internal regulated power supply. Connecting Pin L to Display Input Pin 10 will light the display at full brightness.

Pin M – Offset Voltage Output: 0 to +2.5 V is available with the addition of a $\frac{3}{4}$ " 50 K Ω pot in the R15 position on the printed circuit board. Finer adjustment may be obtained by installing R13 and R14 and cutting open J3 and J4.

Pins N, R, 11, 13, and 15 – No Connection: The PCB pads which would normally correspond to these pins do not exist on the PCB.

Pin P – 117/230 V Select: Connect Pin P to AC Power Input Pin 12 for 117 V operation. Connect Pin P to 117/230 V Select Pin 14 for 230 V operation. (Also see Pin 14.)

Pin S – AC Power Input: Connect one side of 117 or 230 VAC power input to Pin S.

Pin 1 – Auxiliary Divider Low: Pin 1 is the low side of the optional resistor divider represented by R16, R17, and R18. For measuring bridge circuits in the differential ratiometric mode, Pin 1 should be connected to the low side of the excitation voltage source.

Pin 2 – Auxiliary Divider High: Pin 2 is the high side of the optional resistor divider represented by R16, R17, and R18. For measuring bridge circuits in the differential ratiometric mode, Pin 2 should be connected to the high side of the excitation voltage source.

Pin 3 – Signal High Input: Signal high input of the A to D converter. Maximum overvoltage protection is ± 500 VDC or 350 VAC.

Pin 4 – Voltage Divider Signal High Input: Signal high input for voltages that require attenuation or scaling. Dividing resistors R1 and R2 may be mounted internally for voltages up to 1200 V max. Matched dividing resistors for 20 V (1/10), 200 V, (1/100), and 1200 V (1/1000) ranges are available from Texmate. Shunt resistors for current measurements up to 200 mA may be internally mounted in the R2 position. The current loop input is then applied to Signal High Input Pin 3 and returned through Pin H.

Pins 5, 6, 7, and 8 – Decimal Select: Decimal points may be displayed as required by connecting appropriate pin to System Ground Pin K.

Pin 10 – Display Power Input: Power input for LED display drive. For normal operation, connect directly to +5 V Output Pin L. Display may be blanked or dimmed by reducing or removing voltage between Pin 10 and Pin L. The power supply to the A to D converter and logic circuits is independent of that of the display. In the power-conserving "press-to-read" mode, the reading is instantaneously displayed without settling time.

Pin 12 – AC Power Input: Connect one side of 117 or 230 V AC power input to Pin 12.

Pin 14 – 117/230 V Select: Connect Pin 14 to AC Power Input Pin S for 117 V operation. Connect Pin 14 to 117/230 V Select Pin P for 230 V operation. (Also see Pin P.)

Component Layout

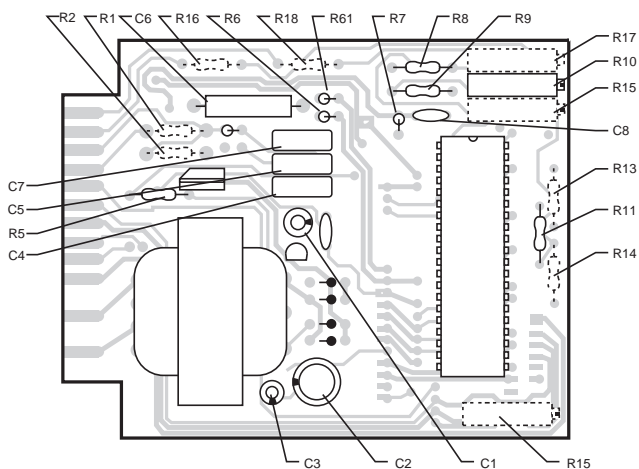

Signal Conditioning Components

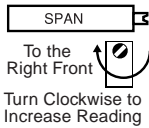

SPAN Potentiometer (Pot)

The SPAN pot is on the right side of the display. Typical adjustment is 20% of the input signal range.

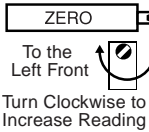

ZERO Potentiometer (Pot) optional

The ZERO pot is on the right side of the SPAN Pot. Typically it enables the displayed reading to be offset ± 500 counts.

Calibration Procedure

Apply power to the meter. Then with a precision DC reference source apply +1.900 VDC between the Signal High Input Pin 3 and Signal Low Input Pin H. Adjust R10 potentiometer (behind front-panel filter on right side as viewed from front) until the display reads +1.900 V. **Note:** The voltage applied in this case is for a +2.000 V full-scale meter. For other ranges, the voltage applied should be similarly proportional to the particular full-scale voltage.

Typical Application Connections

The RP-35A may be used in a wide variety of configurations. The following circuits illustrate some of the possibilities and demonstrate the exceptional versatility of Texmate products. Components called for in the applications which are not part of the standard meter may be supplied by the user or in some cases purchased from Texmate. The circuit diagrams explain the basic pinout connections required for each application. Unless otherwise specified, the diagrams will show the component values and solder junctions that would normally be installed on a standard 2V range meter. For those applications which have alternative ranges and/or input configurations, the required component values and any modifications are described in the text.

DIFFERENTIAL METER WITH EXTERNAL REFERENCE

- 1) Install R16, R17, and R18;
- 2) Reading display = $(V_{in} \div V_{ref}) \times 1000$

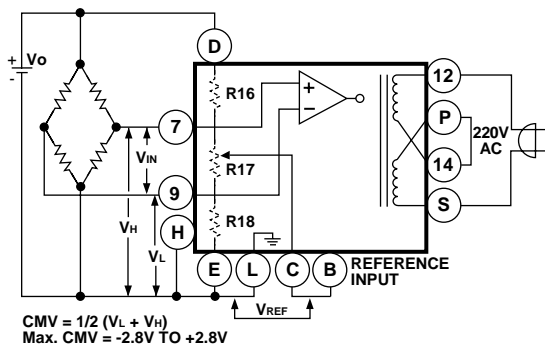

DIFFERENTIAL RATIO-METRIC OHMMETER.

- 1) Install Rs and RT as specified under section titled Useful Tables;
- 2) $(R_S + R_T) \times 2 =$ Full Scale Value;
- 3) $R_x \div (R_S + R_T) \times 1000 =$ Reading Displayed.

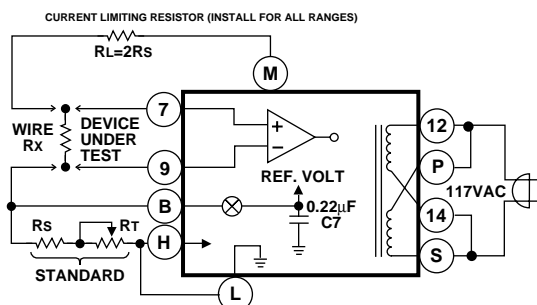

SIMULTANEOUS VOLTAGE AND CURRENT MEASUREMENT

(1) Connect current meter as for 200 mV voltmeter for minimum drop on Rs or R2. Use Rs externally for current greater than 200 mA. (2) Install R1, R2, and Rs as specified under section titled Useful Tables. **NOTE:** Rs must be located in low side of the current loop and Signal Low Input Pin H of the voltage meter must not be grounded.

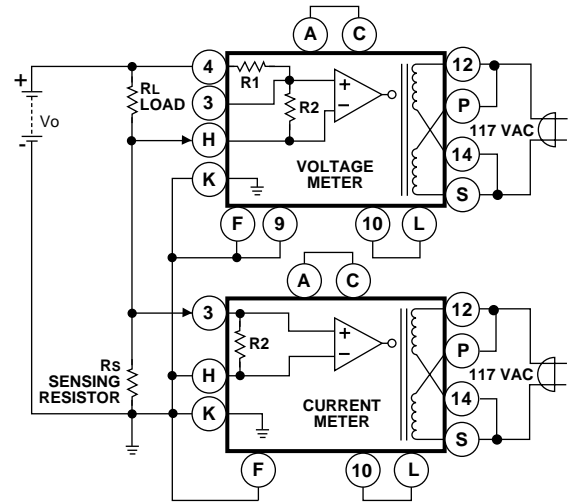

Optional PCB Edge Connector

PCB Edge Connector

A standard 30-pin edge connector (two rows of 15 pins on 0.156" centers) may be used to connect the RP-Series of meters. Order part no. CN-L15.



Face Plate Descriptors

Volts AC	Volts DC	Hz	RPM
Amps AC	Amps DC	DC μ A	
Milliamps AC	Milliamps DC	°C	
Millivolts AC	Millivolts DC	°F	
Kilowatts	Watts	% pH	Ω
kg/cm ²	Kilovolts AC	psi	
kWH	kVAR	Power Factor	
k Ω	Cos θ	M/min	m ³ /hr

To customize the face plate, each RP-meter is supplied with a white printed clear adhesive label containing various popular descriptors. Choose the descriptor, peel off the adhesive backing and align the descriptor in the lower right corner of the standard face plate.

Custom Face Plates

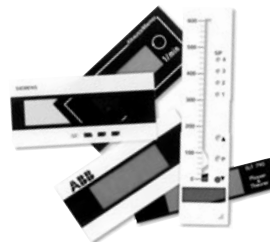

Texmate Produces Thousands of Custom OEM Face Plates

Have Texmate Design and produce a Custom Face Plate for your next project!

- Custom face plates have a non-recurring artwork charge. A serial number is then assigned to each artwork to facilitate reordering.

- Small Run or One-Off custom face plates incur an installation charge, and are generally printed on a special plastic film, which is then laminated to custom faceplate blanks as required.

- Large Run (250 pieces min): custom face plates are production silk screened, issued a part number, and held in stock for free installation as required by customer orders.

- OEMs may also order Custom Meter Labels, Box Labels, Custom Data Sheets and Instruction Manuals.

RP Case Dimensions and Panel Cutouts

This NEMA Case will fit any existing cutout with dimensions that are between the Snug and Loose Fitting dimensions shown below.

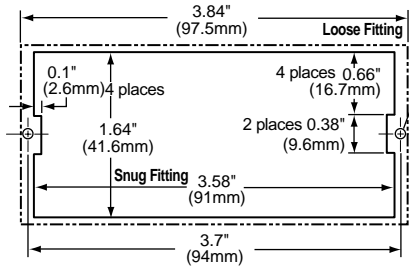

Panel Cutout for Front Panel Removal

To enable removal of the panel meter from a mounting panel without requiring rear access, make the panel cutout as shown above, using the mounting plate supplied with the meter as a template. The mounting holes should then be tapped to match the mounting screws.

To remove the face plate, carefully insert screwdriver blade at bottom slot to release catch and gently pry outward to release the plate.

For new installations see Optimum Panel Cutout or Panel Cutout for Front Panel Removal

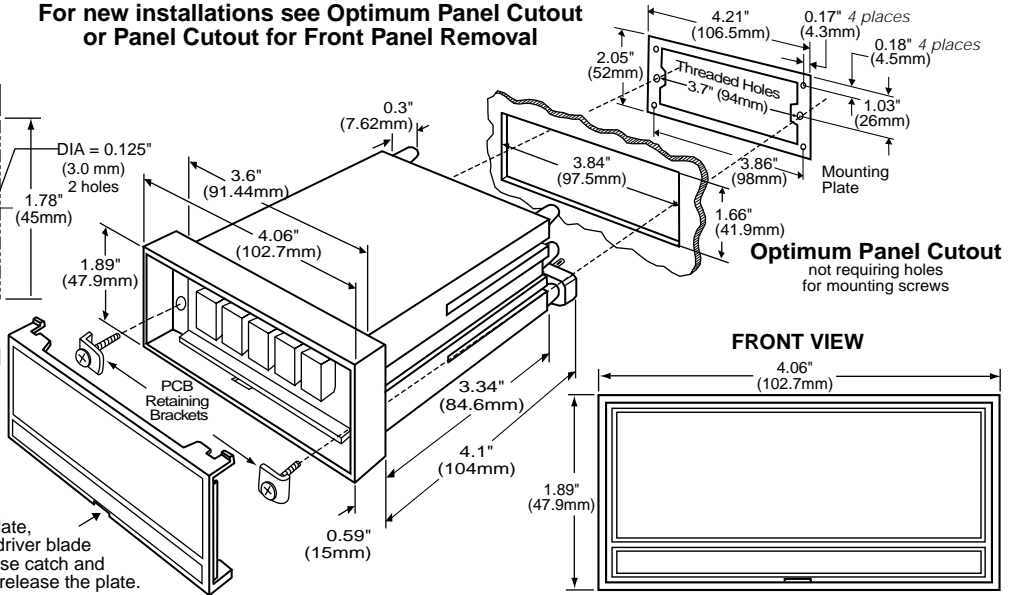

Ordering Information

Standard Options for this Model Number

Part Number .Description

► BASIC MODEL NUMBER

RP-35A3.5 digit Red LED, w/Differential Inputs, 2VDC std

Special Options and Accessories

Part Number .Description

► SPECIAL OPTIONS (Specify Inputs & Req. Reading)

- VA-200MVFI200mVDC Range Change
- VF-0020V20VDC Range Change
- VF-0200V200VDC Range Change for 3.5 digit RP Series
- VF-1200V1200VDC Range Change for 3.5 digit RP Series
- VS-3.5Non-Std Range and Scale - 3.5 Digit RP Meters

► ACCESSORIES

- CN-L15PCB Edge Connector, Solder Type, Dual row 15 Pins
- OP-NSEAL/UM96x48mm clear lockable front cover - NEMA 4X, splash proof for RP & UM Series (Factory Installed)
- RPCASEReplacement Case w/Mounting Hardware

Prices subject to change without notice.

WARRANTY

Texmate warrants that its products are free from defects in material and workmanship under normal use and service for a period of one year from date of shipment. Texmate's obligations under this warranty are limited to replacement or repair, at its option, at its factory, of any of the products which shall, within the applicable period after shipment, be returned to Texmate's facility, transportation charges pre-paid, and which are, after examination, disclosed to the satisfaction of Texmate to be thus defective. The warranty shall not apply to any equipment which shall have been repaired or altered, except by Texmate, or which shall have been subjected to misuse, negligence, or accident. In no case shall Texmate's liability exceed the original purchase price. The aforementioned provisions do not extend the original warranty period of any product which has been either repaired or replaced by Texmate.

USER'S RESPONSIBILITY

We are pleased to offer suggestions on the use of our various products either by way of printed matter or through direct contact with our sales/application engineering staff. However, since we have no control over the use of our products once they are shipped, NO WARRANTY WHETHER OF MERCHANTABILITY, FITNESS FOR PURPOSE, OR OTHERWISE is made beyond the repair, replacement, or refund of purchase price at the sole discretion of Texmate. Users shall determine the suitability of the product for the intended application before using, and the users assume all risk and liability whatsoever in connection therewith, regardless of any of our suggestions or statements as to application or construction. In no event shall Texmate's liability, in law or otherwise, be in excess of the purchase price of the product.

Texmate cannot assume responsibility for any circuitry described. No circuit patent or software licenses are implied. Texmate reserves the right to change circuitry, operating software, specifications, and prices without notice at any time.



995 Park Center Drive • Vista, CA 92081-8397
 Tel: 1-760-598-9899 • USA 1-800-839-6283 • That's 1-800-TEXMATE
 Fax: 1-760-598-9828 • Email: sales@texmate.com • Web: www.texmate.com

Texmate has facilities in Japan, New Zealand, Taiwan, and Thailand. We also have authorized distributors throughout the USA and in 28 other countries.

For product details visit www.texmate.com

Local Distributor Address